

Replacing Paper Roll

Open the receipt paper hatch.

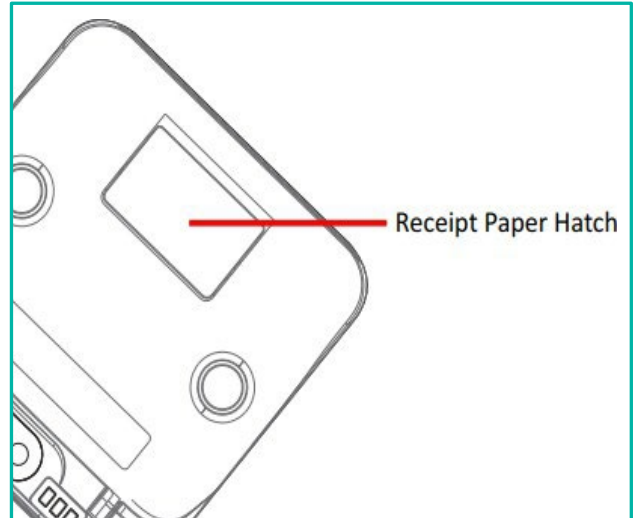

Insert a new paper roll as per the diagram provided, making sure the paper comes out from the top of the roll.

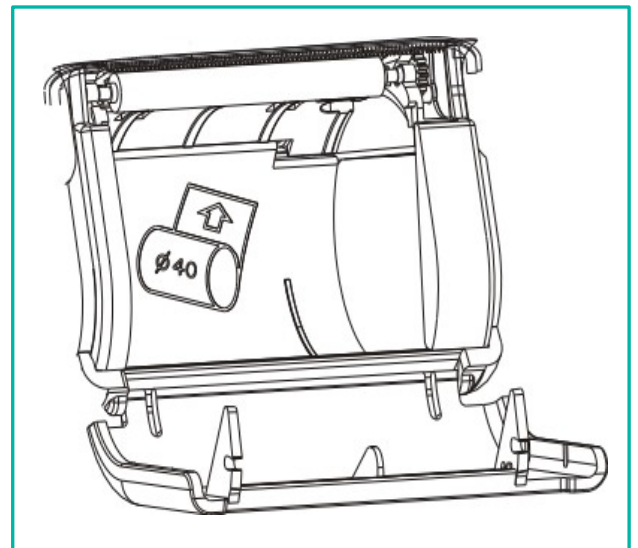

Pull approximately 6 inches of paper from the roll and then press the paper hatch closed until it snaps into place.

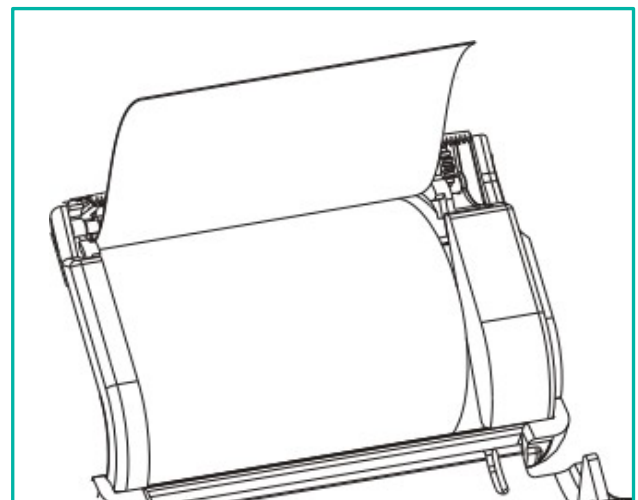

Tear any excess paper up and away from the device at a 45-degree angle.